

A Winning Bet with Comba Solutions

Ensuring multi-system, multi-operator coverage for Macau's landmark entertainment and casino complex



About the Grand Waldo

The Grand Waldo is an integrated entertainment complex located on Macau's Cotai Strip – an area earmarked for hotel, casino and entertainment businesses. Developed by Galaxy Entertainment, the complex was the first to open on the Strip.

Covering over 84,200 square meters, the Grand Waldo consists of three blocks housing a hotel, casino, spas, restaurants, bars, clubs and retail shops.

- Casino block of 6 floors
- Entertainment block of 7 floors
- Hotel block of 12 floors
- A large central auditorium
- Multi-level car park

Executive Summary

Often touted as the "Las Vegas of the East", Macau is a special administrative region of China where the economy is based on tourism and specifically gambling. According to the World Tourism Organization, Macau ranks 21st in terms of tourist arrivals and 24th for tourism receipts.

The opening of Macau's gambling industry in 2002 ushered in a boom to the local economy with rapid development of resorts, casinos and hotels. As part of this boom, reclaimed land that was eventually designated *Cotai* was created as a new gambling and tourism hub since Macau is so densely populated and land is scarce.

Galaxy Entertainment's Grand Waldo Hotel and Casino complex was the first to commence operations in Cotai. With a target audience of high-end visitors and high-rollers, it was essential that the entire project be perfect from the building structure and decorations to telecoms infrastructure and coverage as befitting the image.

Based on its expertise, flexibility, solutions package and flexibility, Comba Telecom was selected to commission a multi-system, multi-carrier, in-building wireless system to enable ubiquitous mobile phone coverage for users.

Comba Telecom is one of the world's leading suppliers of in-building wireless systems and has deployed over 50,000 such installations around the world.

The Objectives

The Grand Waldo Casino and Hotel is the first integrated entertainment resort to be developed in Macau by the Galaxy Entertainment Group. During its construction, Comba Telecom was contracted by the consortium of incumbent mobile operators led by Smartone Macau to enable wireless coverage in all parts of the completed project.

Comba's brief was to design and supervise installation of an end-to-end 2G multi-carrier in-building wireless coverage system, and to also design the system to be easily upgradeable to 3G when required. The deadline for completion was within six months and before the grand opening.

Technical Objectives

With four different carriers, each with their network requirements, the objective was to implement a resilient system with shared resources to maintain efficiencies and to minimize disruption to the site construction and operations.

The number of networks required was thus:

- 3 × GSM900 networks
- 3 × GSM1800 networks
- 1 × CDMA800 network
- 2 × WCDMA ready networks

Technical targets for signal quality included the following:

- Overall system quality (including car parks and building structures):
 - RxQUAL within 0 -3
 - CPICH RSCP > -90 dBm
 - RxLev ≥ -95dBm in elevators

Case Study

Grand Waldo, Macau

- GSM900 and GSM1800 minimum DL RxLev:
 - > -85dBm in 98% of designated areas
 - > -90dBm in elevators and car parks
- CDMA800 minimum CPICH Ec/Io:
 - > -6dB in 98% of designated areas
 - > -7dB in elevators and car parks
- Call connection rate \geq 98%
- For WCDMA, minimum CPICH Ec/Io of -12 dB

Definition of terms:

RxQUAL	received signal quality
RxLev	received signal level
CPICH	common pilot channel
Ec/Io	pilot strength
RSCP	received signal code power

Installed Solution

Defining sectors

After extensive capacity analysis, Comba divided the complex into two main coverage sectors: one sector for the hotel and the other covering the casino and entertainment blocks. Each sector would be served by at least one base station with signal handovers between inner and outer cells fully supported.

Minimizing system footprint

In order to minimize the footprint of the system, Comba accommodated all of the repeater master units and indoor boosters within a single base transceiver station (BTS) room at the top floor of the hotel. This BTS room serviced all three blocks through distributed antenna systems (DAS).

Optimal placement of indoor antennas was determined by a signal transmitter to gauge penetration losses and positioning.

Expecting the unexpected

With the grand opening of the complex less than six months away, the designs and layout of the complex were still in flux as the owners sought to optimize the complex to provide the best-in-class experience for its future customers. Due to the rapid nature of the changes, the latest layouts were at times not communicated to all levels.

As such, Comba experienced a number of unexpected situations where there were mismatches between the layout

plans and the reality such as differing size of rooms and even “missing” or “extra rooms” which would impact signal quality. Since time was of the essence, Comba assigned a dedicated on-site project manager to make the necessary “on the spot” system design changes to ensure consistent signal quality.

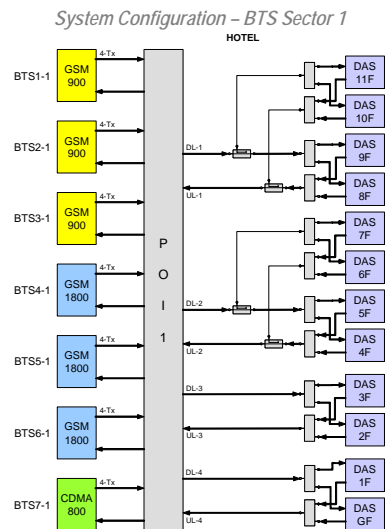

The hotel was served by 180 antennas to cover almost 25,000 m² over 11 floors and 4 elevators

The Results

After extensive trials and post-installation testing, Smartone Macau and the Grand Waldo complex was equipped with a wireless communications system for both in-building and outdoor coverage that met and exceeded the targets well within the timeline and before the grand opening of the complex:

- 100% wireless coverage within the complex
- Scalability for future voice/data capacity requirements
- 3G upgradable system
- 24/7 support services

As an added precaution, Comba’s team was on standby before, during and after the opening to ensure glitch-free operations.

Mr. Kevin Ma, Comba’s Project Engineer leading the installation said “The

installation of the wireless system for the Grand Waldo is a landmark project for a number of reasons. For the user, it was the first integrated entertainment resort with ubiquitous coverage. For the local telecoms industry, it was a milestone where the Grand Waldo is the first active system implemented where all operators collaborated to share and optimize resources.”

Comba Products and Services

- Semi-turnkey in-building coverage design, installation supervision, project management, commissioning and ATP
- Active optical Repeaters : CDMA800(10w)GSM900 (10w), DCS1800 (10w), UMTS (20w)
- Custom-made POI for a shared antenna system
- Wideband omni-directional indoor antennas and passive components

For more information, contact your Comba representative, or visit <http://www.comba-telecom.com>

The products and services described in this publication are subject to availability and may be modified from time to time. Services and equipment are provided subject to Comba Telecom Limited’s conditions of contract. Nothing in this publication forms any part of any contract.

